

22 11 10

DIN 333 RH

HSS

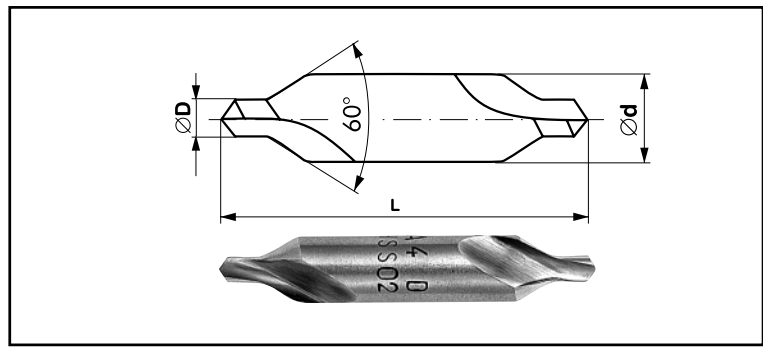

D mm	L mm	dh7 mm
1,00	31,5	3,15
1,25	31,5	3,15
1,60	35,5	4,00
2,00	40,0	5,00
2,50	45,0	6,30
3,15	50,0	8,00
4,00	56,0	10,00
5,00	63,0	12,50
6,30	71,0	16,00

22 11 12

DIN 333 RH

B HSS

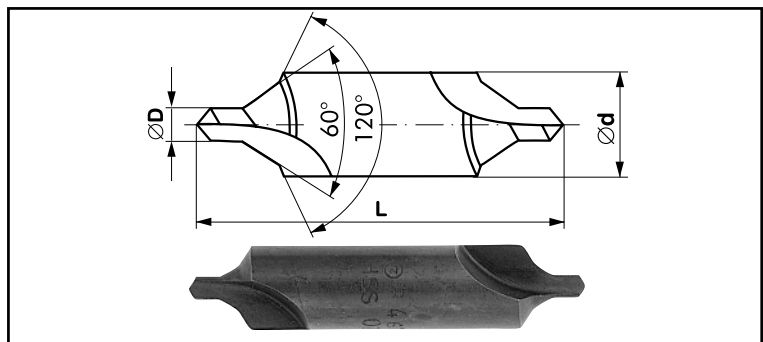

D mm	L mm	dh7 mm
1,00	35,5	4,00
1,25	40,0	5,00
1,60	45,0	6,30
2,00	50,0	8,00
2,50	56,0	10,00
3,15	60,0	11,20
4,00	67,0	14,00
5,00	75,0	18,00
6,30	80,0	20,00

22 11 16

DIN 333 RH

R HSS

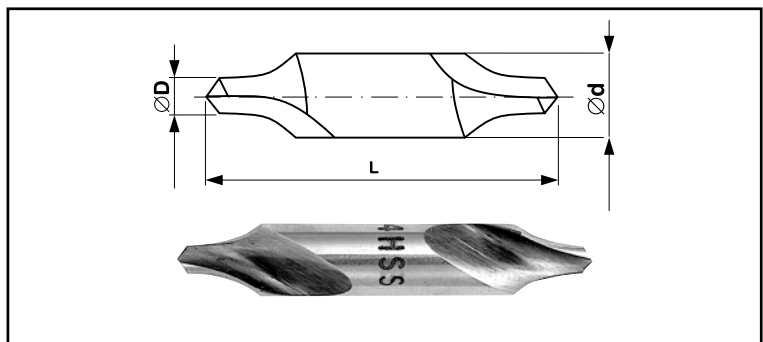

D mm	L mm	dh7 mm
1,00	31,5	3,15
1,25	31,5	3,15
1,60	35,5	4,00
2,00	40,0	5,00
2,50	45,0	6,30
3,15	50,0	8,00
4,00	56,0	10,00
5,00	63,0	12,50
6,30	71,0	16,00